

# BOMBA DE VACÍO EKC 405

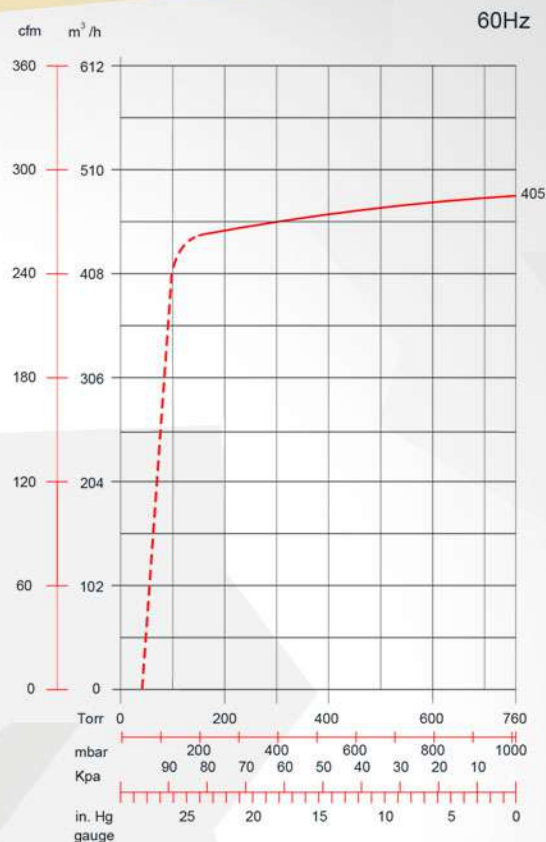

## Especificaciones

|                         |                        |                         |              |
|-------------------------|------------------------|-------------------------|--------------|
| <b>Motor (kW)</b>       | 9.2                    | <b>dB (A), Máx</b>      | 78           |
| <b>Vacío Máx (inHg)</b> | 28.4                   | <b>Aceite (Cuartos)</b> | 1.5          |
| <b>Flujo (m³/h)</b>     | 480                    | <b>Conexiones (NPT)</b> | 3"           |
| <b>Amperaje</b>         | -----                  | <b>Temp. Ambiente</b>   | 5 °C ~ 40 °C |
| <b>Voltaje</b>          | 220 ~ 240 / 380 ~ 420V | <b>Peso (kg)</b>        | -----        |

## Dimensiones

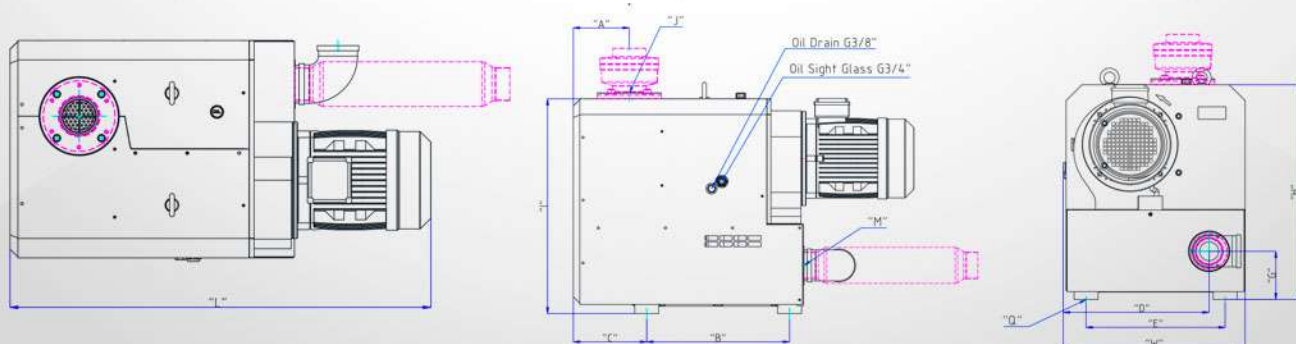

| Dimension (mm)        | L           | W   | H   | A   | B   | C   | D   | E   | F   | G   | I   | J  | M      | Q       |
|-----------------------|-------------|-----|-----|-----|-----|-----|-----|-----|-----|-----|-----|----|--------|---------|
| EKC-405 7.5Kw / 9.2Kw | 1065 / 1105 | 569 | 684 | 175 | 447 | 230 | 457 | 435 | 374 | 153 | 684 | 3" | 2-1/2" | M12 Tap |