

BOMBA DE VACÍO EKC 515

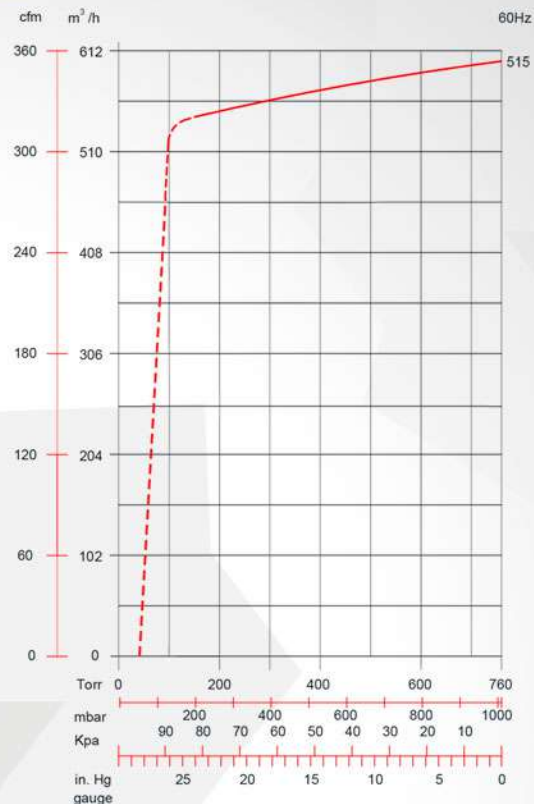

Especificaciones

| | | | |
|-------------------------|------------------------|-------------------------|--------------|
| Motor (kW) | 11 | dB (A), Máx | 78 |
| Vacío Máx (inHg) | 28.4 | Aceite (Cuartos) | 1.5 |
| Flujo (m³/h) | 600 | Conexiones (NPT) | 3" |
| Amperaje | ----- | Temp. Ambiente | 5 °C ~ 40 °C |
| Voltaje | 220 ~ 240 / 380 ~ 420V | Peso (kg) | ----- |

Dimensiones

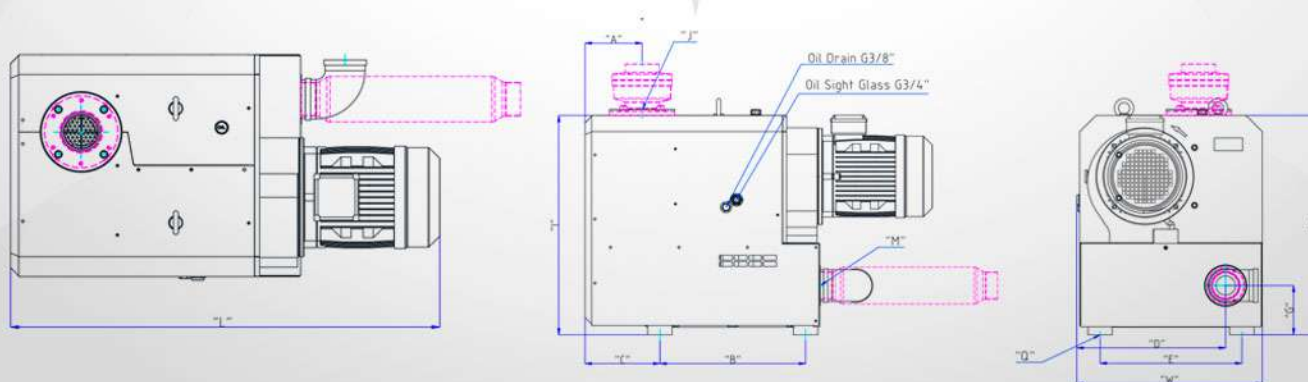

| Dimension (mm) | L | W | H | A | B | C | D | E | F | G | I | J | M | Q |
|------------------------|-------------|-----|-----|-----|-----|-----|-----|-----|-----|-----|-----|----|--------|---------|
| EKC-515 9.2Kw / 11Kw | 1105 / 1275 | 569 | 684 | 160 | 447 | 230 | 457 | 435 | 374 | 153 | 684 | 3" | 2-1/2" | M12 Tap |