

# PALETAS LUBRICADAS

# EKL 320 & 430

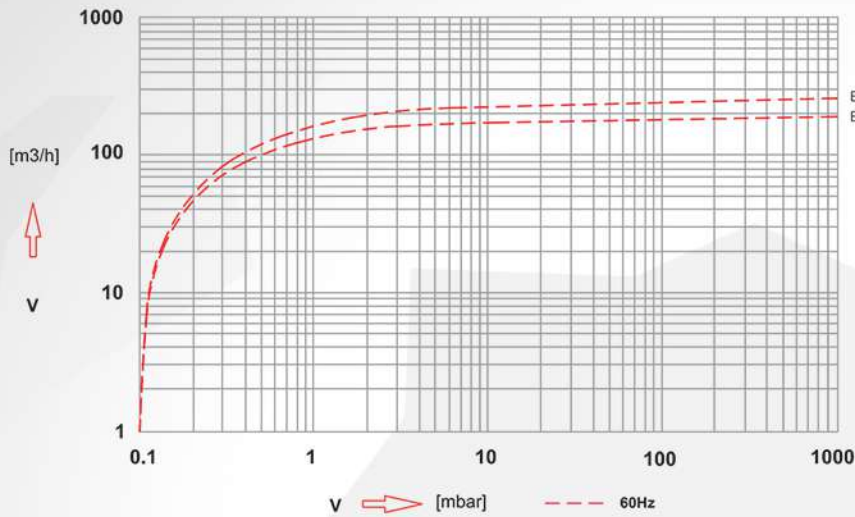

Especificaciones					
Modelo	320	430	Modelo	320	430
Flujo (m <sup>3</sup> /h)	192	258	Vacío máx (inHg)	29.9	29.9
Motor (Kw)	3.7	5.5	Aceite (Cuartos)	8	8
Amperaje	---	---	Conexiones (NPT)	2"	2"
RPM	1740	1740	Temp. Ambiente	85 °C	85 °C
Ruido (dB (A))	75	77	Peso (Kg)	124	145

## Dimensiones

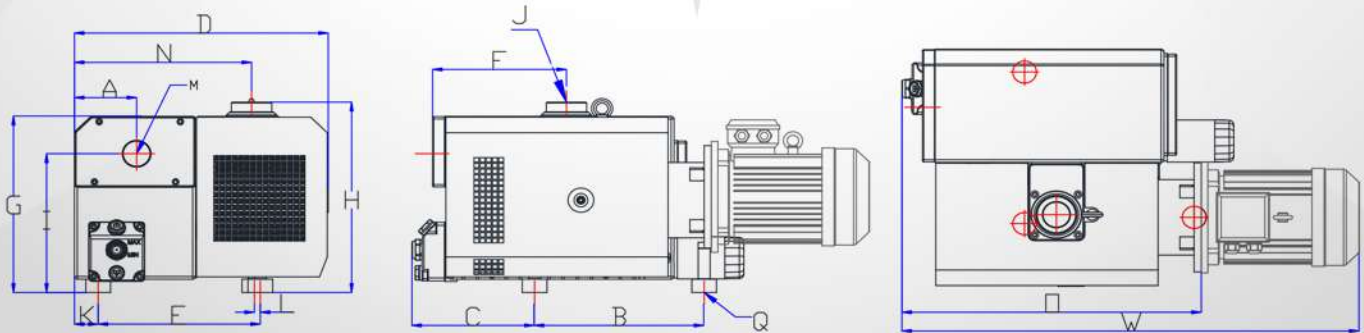

MODEL	W	D	H	A	B	C	E	F	G	I	J	K	L	M	N	O	Q
EKL-320	903	535	429	131	297	257	366	282	397	313	G 2"	50	12.5	G 2"	373	570	3xM10
EKL-430	962	535	429	131	357	257	366	282	397	313	G 2"	50	12.5	G 2"	373	630	3xM10