

SOPLADOR TIPO GARRA EPC 255

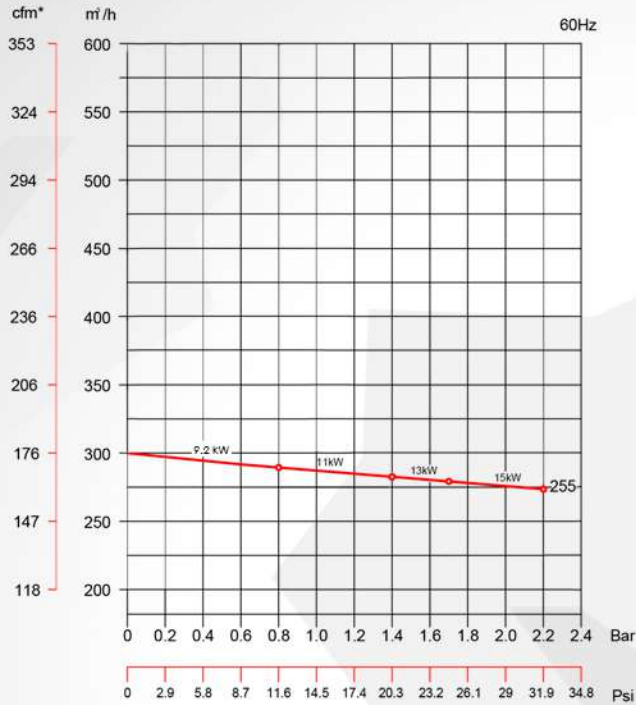

Especificaciones

Motor (kW)	9.2	11	13	15	dB (A), Máx	82
Presión Máx (psi)	11.6	20.3	24.6	31.9	Aceite (Cuartos)	0.9
Flujo (m³/h)	300				Conexiones (NPT)	2"
Voltaje	220 ~ 240 / 380 ~ 420V				Temp. Ambiente	5 °C ~ 40 °C

Dimensiones

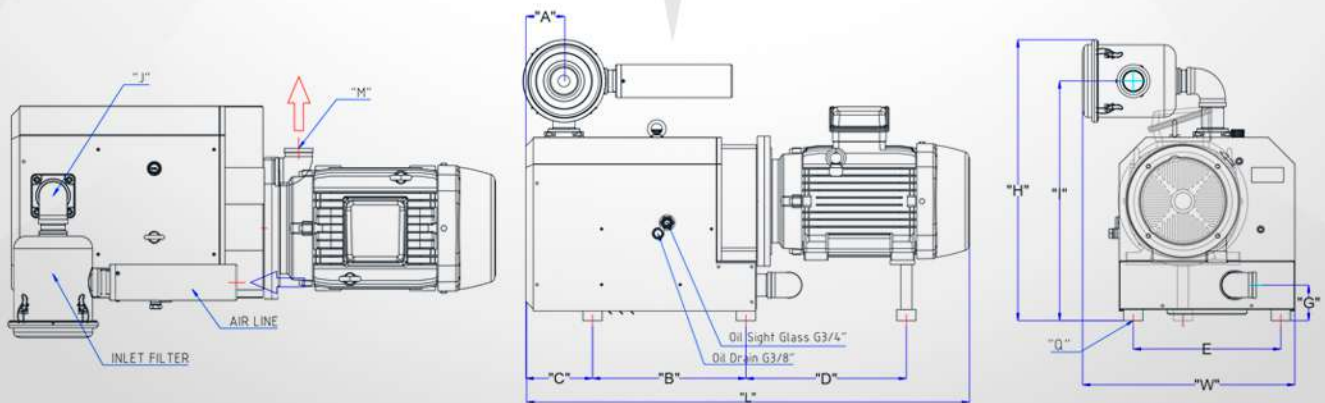

DIMENSIONS (mm)		L	W	H	A	B	C	D	E	G	I	J	M	Q
EPC - 255	9.2kW, 11kW, 13kW, 15kW	961 / 1001 / 1171	573	757	103	490	166	// 379	398	96	646	2"	2"	M10 Tap