

APPLICAZIONI

Vasche di nitrificazione /denitrificazione
Vasche di trattamento fanghi attivi
Vasche di clorazione
Miscelazioni industriali

CARATTERISTICHE TECNICHE

Elica a pale regolabili
Riduttore epicicloidale a due stadi in bagno d'olio
Pale in poliammide e fibra di vetro
Mozzo elica acciaio inox
Carcassa motore e riduttore in ghisa
Viti e sistema di sollevamento in acciaio inox
Separazione galvanica dei componenti

APPLICATIONS

Nitrification/De-nitrification tanks
Sludge treatment tanks
Chlorination tanks
Industrial mixing

TECHNICAL FEATURES

Adjustable propeller blades
Two step planetary gearbox, oil filled
Polyamide and fibreglass blades
Propeller hub in stainless steel
Motor housing and planetary gear in cast iron
Bolts/Nuts and motor bracket in stainless steel
Galvanic separation of all built-in parts

APPLICATIONS

Bassin de nitrification/dénitrification
Bassin de traitement des boues activées
Bassin de chloration
Mélange industriel

CARACTERISTIQUES TECHNIQUES

Helice à aubes réglables
Réducteur épicycloïdal à bain d'huile
Pales en polyamide et fibres de verre
Moyeu de l'hélice en acier inox
Carcasse moteur et réducteur en fonte
Visserie et système de relevage en acier inox
Séparation galvanique des composants



DIAGRAMMA PRESTAZIONI

Estensione flusso per velocità v = 0,3 m/s in acqua pulita

PERFORMANCE DIAGRAM

Flow extension for speed v = 0,3 m/s in clean water

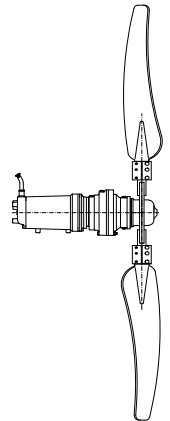
DIAGRAMME PERFORMANCE

Extension du flux pour vitesse v = 0,3 m/s en eau propre

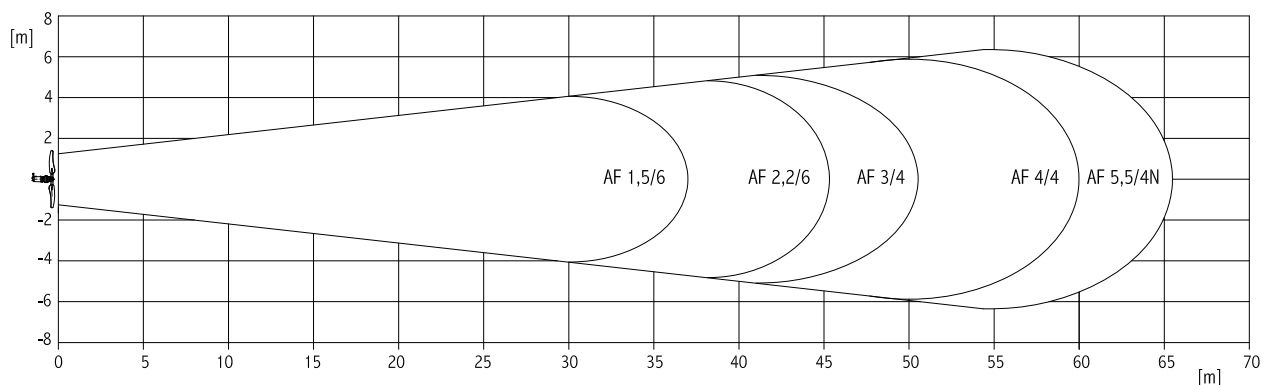

CARATTERISTICHE MOTORI TRIFASE - 50 Hz - ALIMENTAZIONE 400 V ±10%
50 Hz - THREE-PHASE-MOTOR FEATURES - VOLTAGE RATING 400 V ±10%
CARACTERISTIQUES DES MOTEURS TRIPHASES - 50 Hz - ALIMENTATION 400 V ±10 %

CARATTERISTICHE MISCELATORE
MIXER CHARACTERISTICS
CARACTERISTIQUES MELANGEUR

Tipo Type Type	Potenza motore Motor rating Puissance moteur	Avvolgimenti Windings Bobinages	Assorbimento Absorption Intensité	Giri/min RPM T/min	Cavo - Cable - Cable			Avviamento		N° Pale N° Blades N° Pales	Ø Pale Ø Blades Ø Pales	Giri/min RPM T/min	Portata Capacity Débit	Spinta assiale* Axial force* Poussée axiale*		
	[kW]	[V]	[A (400V)]	n	N°cavi N°cables N°cables	N° conduttori cavo x sezione N° of wires x size N° conducteurs câble à section	Lunghezza cavo Cable length Longueur câble	Diretto Direct Direct	△						[mm]	[m ³ /h]
AF 1,5 / 6	1,5	230-400	4,2	925	1	9 x 1,5	10	△	△	2	2280	32,3	11490	1226		
AF 2,2 / 6	2,2		5,9	940											△	△
AF 3 / 4	3		6,4	1420												
AF 4 / 4	4	400-690	9,1	1405				△	△-△							
AF 5,5 / 4N	5,5		12,5	1430											△	△-△
												34,1	14716	2011		
												33,7	16250	2452		
												34,4	17803	2943		

* Valori ricavati in accordo alla ISO 21630
* Values according to ISO 21630
* Les valeurs obtenues sont conformes à l'ISO 21630

CARATTERISTICHE STANDARD

Motori elettrici asincroni trifase con rotore a gabbia di scoiattolo.
N°2 sonde termiche inserite nell'avvolgimento statorico.
Grado di protezione "IP 68".
Isolamento classe "F".
Max profondità immersione 20 m.
Max contenuto sostanze solide in sospensione 8%.
Cavo sommersibile in neoprene H07-RN-F.
pH liquido 5 ÷ 12
Max temperatura del liquido pompato 40°C.
Servizio continuo.

STANDARD FEATURES

Asynchronous three phase electric motors with squirrel cage rotor.
N.2 thermic probes installed in the stator winding.
Protection "IP 68".
"F" class insulation.
Max submergence depth: 20 m.
Max solid content in the liquid: 8%.
Submersible H07-RN-F neoprene cable.
Liquid pH 5 - 12.
Max temperature of pumped liquid: 40°C.
Continuous service.

CARACTERISTIQUES STANDARD

Moteurs électriques asynchrones triphasés, rotor à cage d'écureuil.
N°2 sondes thermiques incorporées dans l'enroulement du stator.
Degré de protection "IP 68".
Isolement classe "F".
Max profondeur d'immersion 20 m.
Max contenu de substances solides en suspension 8%.
Max pH du liquide 5 ÷ 12.
Câble submersible en néoprène H07-RN-F.
Max température du liquide pompé 40°C.
Service continu.

Tipo Type Type	Motore Motor Moteur	DIMENSIONI INGOMBRO OVERALL DIMENSIONS DIMENSIONS [mm]					Peso Weight Poids
	[kW]	A	B	∅C	D	E	[kg]
AF 1,5 / 6	1,5	885	2280	100	450	420	106
AF 2,2 / 6	2,2						107
AF 3 / 4	3						122
AF 4 / 4	4						125
AF 5,5 / 4N	5,5	955				445	150

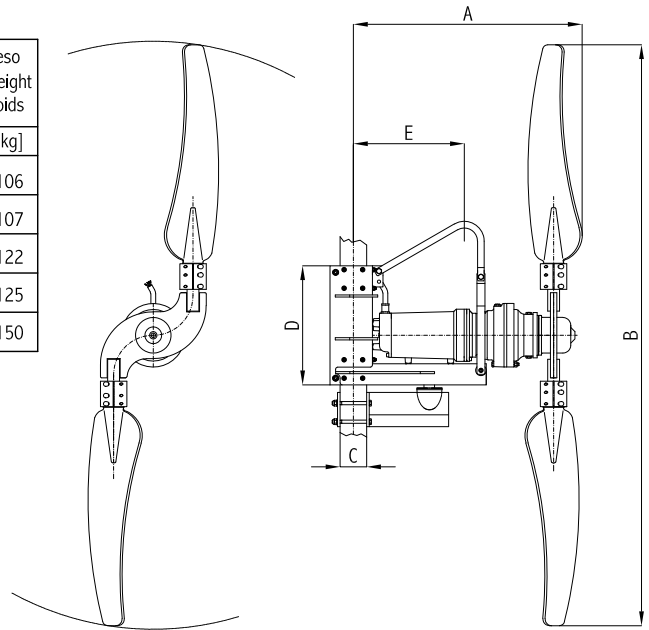

Tutti gli Acceleratori di Flusso serie AF sono fissati ai rispettivi attacchi palo SFO in modo da essere galvanicamente isolati.

All AF Series Flow Accelerators are fixed to their SFO motor brackets with a galvanic insulation.

Tous les Accélérateurs de Flux série AF sont fixés aux respectifs supports du moteur SFO, afin qu'ils soient galvaniquement isolés.

INSTALLAZIONE - INSTALLATION - INSTALLATION

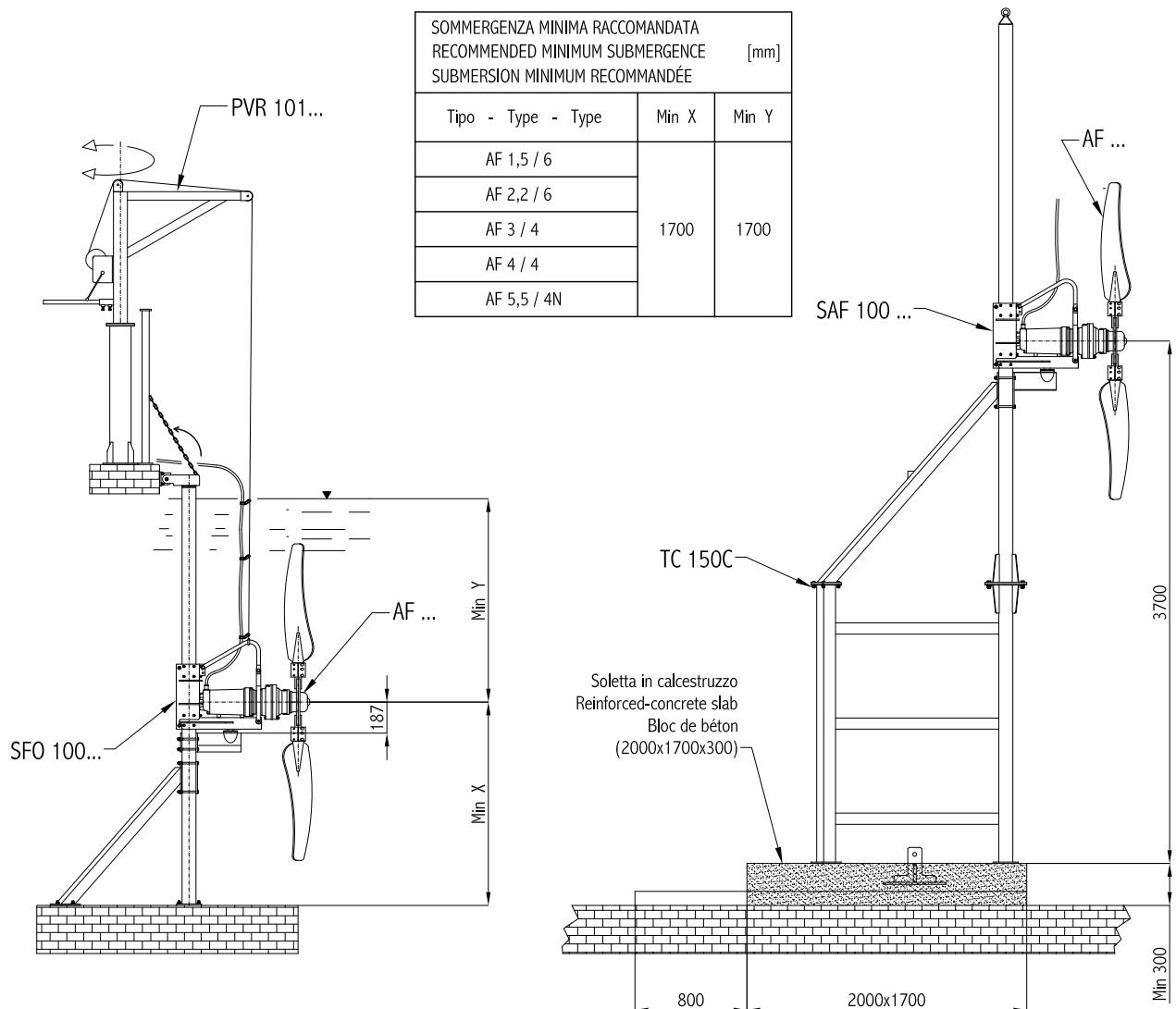

INSTALLAZIONE - INSTALLATION - INSTALLATION

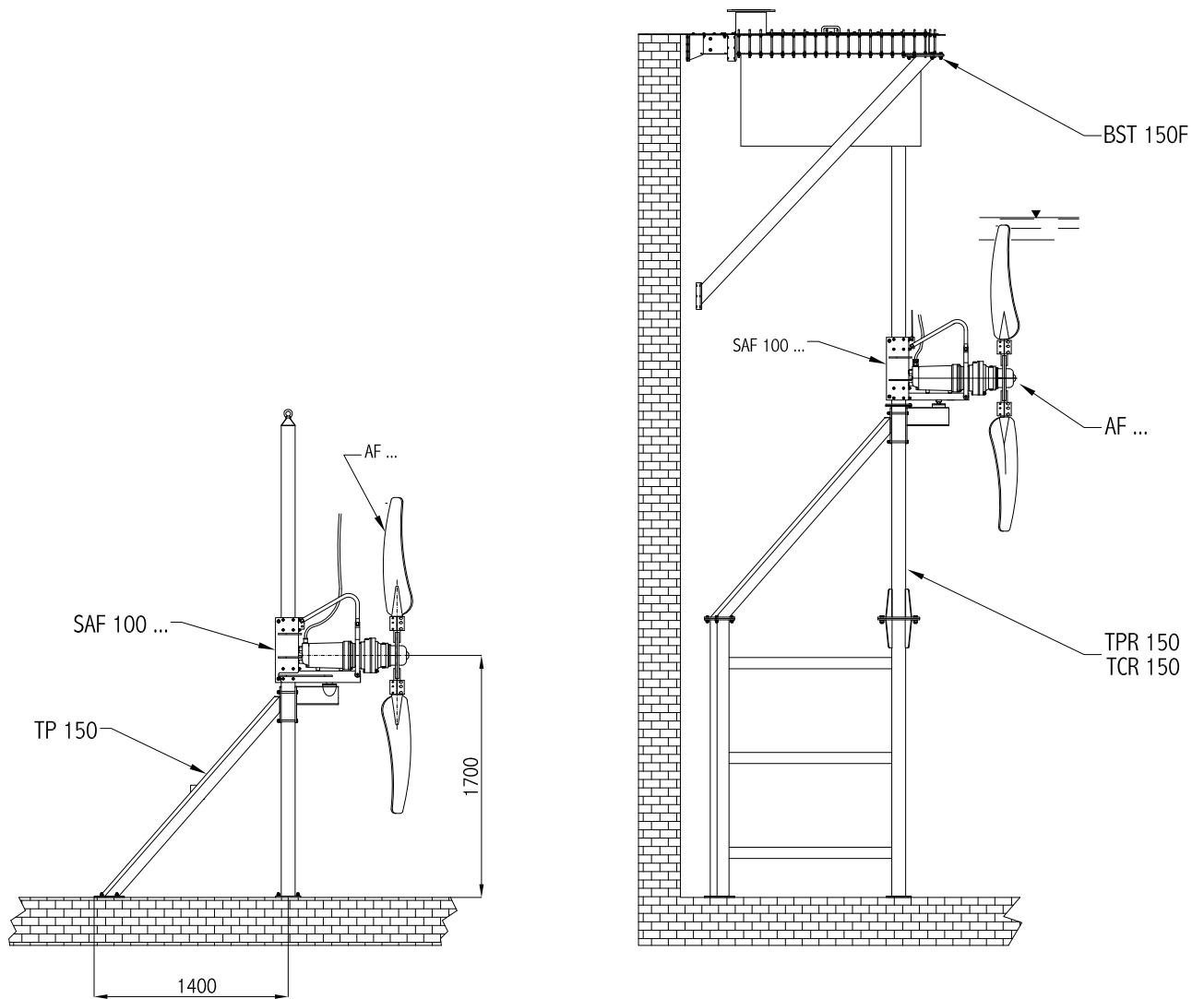

ACCESSORI - ACCESSORIES - ACCESSOIRES

Sistemi di sollevamento
 Lifting system for flow accelerators
 Potence pour accélérateurs de flux

Gru con verricello e tubo guida
 Cranes winch and rail pipe
 Grues poulie et tuyau guide

Staffa motore
 Motor bracket
 Support de moteur

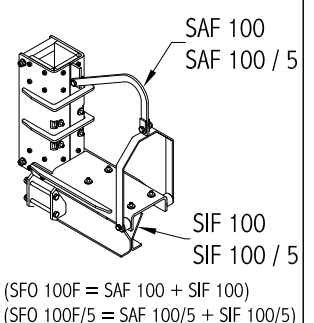
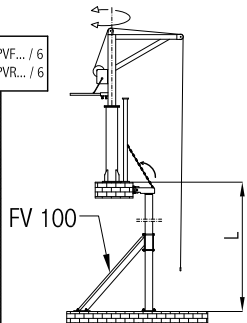
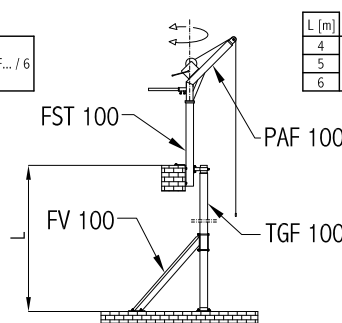
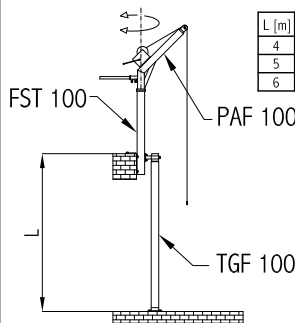

(SFO 100F = SAF 100 + SIF 100)
 (SFO 100F/5 = SAF 100/5 + SIF 100/5)

CRI-MAN 2019

AF 1,5 / 6	PVF 100 / 6	PVR 101 / 6	SFO 100F
AF 2,2 / 6	(PAF 100 + FST 100 + TGF 100)		
AF 3 / 4	PVF 101 / 6		
AF 4 / 4	(PAF 100 + FST 100 + TGF 100 + FV100)		
AF 5,5 / 4N			SFO 100F / 5

ACCESSORI - ACCESSORIES - ACCESSOIRES

		Tripode Tripod stand Trépied				
Tipo Type Type		Per fissaggio a fondo vasca For bottom tank installation Pour installation au fond de fosse	Per fissaggio su soletta in calcestruzzo poggiata a fondo vasca On reinforced-concrete slab, for bottom tank installation Fixé sur un bloc de béton, pour inst. au fond de fosse	Staffa motore per tripode Motor bracket Support de moteur	Fune per recupero miscelatore Rope for mixer extraction Câble extraction du mélangeur	
AF 1,5 / 6		TP 150	TP 150C	SAF 100	FUR 8x6	
AF 2,2 / 6						
AF 3 / 4						
AF 4 / 4						
AF 5,5 / 4N				SAF 100 / 5		
		Tripode rialzato con traliccio Tripod stand with trestle Trépied avec treillis				
Tipo Type Type		Per fissaggio a fondo vasca For bottom tank installation Pour installation au fond de fosse	Per fissaggio su soletta in calcestruzzo poggiata a fondo vasca On reinforced-concrete slab, for bottom tank installation Fixé sur un bloc de béton, pour inst. au fond de fosse	Staffa motore per tripode Motor bracket Support de moteur	Fune per recupero miscelatore Rope for mixer extraction Câble extraction du mélangeur	
AF 1,5 / 6		TC 150	TC 150C	SAF 100	FUR 8x6	
AF 2,2 / 6						
AF 3 / 4						
AF 4 / 4						
AF 5,5 / 4N				SAF 100 / 5		
		Accessori per Biogas Biogas accessories Accessoires pour Biogaz				
Tipo Type Type		Balcone per teloni Balcony for gasholder Balcon pour bâche	Tripode rotante Rotating tripod stand Trépied rotatif	Tripode rotante rialzato con traliccio Rotating tripod stand with trestle Trépied rotatif avec treillis	Staffa motore per tripode Motor bracket Support de moteur	Kit tasselli di fissaggio Fixing dowel kit Kit goujon de fixation
AF 1,5 / 6		BST 150F	TPR 150	TCR 150	SAF 100	KIT BST 150
AF 2,2 / 6						
AF 3 / 4						
AF 4 / 4						
AF 5,5 / 4N					SAF 100 / 5	