

TBM 1,5 / 6N	TBM 11 / 4
TBM 2,2 / 6N	TBMex 11 / 4
TBM 2,2 / 4	TBM 15 / 4N
TBMex 2,2 / 4	TBMex 15 / 4
TBM 3 / 4	TBM 18,5 / 4N
TBMex 3 / 4	TBMex 18,5 / 4
TBM 4 / 4	TBM 22 / 4
TBMex 4 / 4	TBM 25 / 4
TBM 5,5 / 4N	
TBMex 5,5 / 4	
TBM 7,5 / 4N	
TBMex 7,5 / 4	
TBM 9 / 4N	
TBMex 9 / 4	

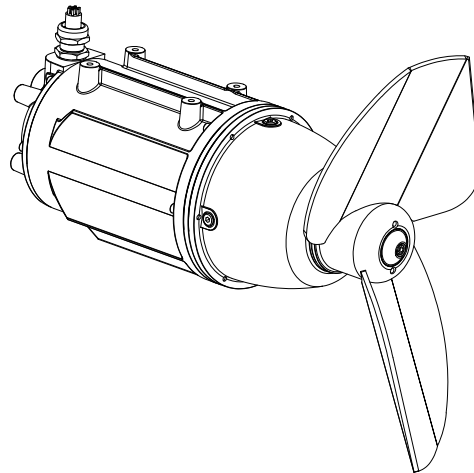

### DIAGRAMMA PRESTAZIONI

Estensione flusso per  $v = 0,3$  m/s in acqua pulita

### PERFORMANCE DIAGRAM

Flow extension for speed  $v = 0,3$  m/s in clean water

### DIAGRAMME PERFORMANCE

Extension du flux pour vitesse  $v = 0,3$  m/s en eau propre

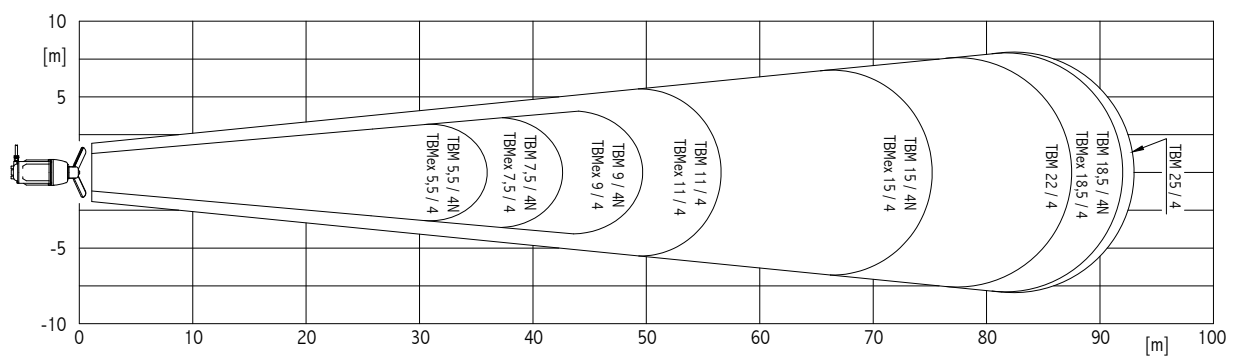
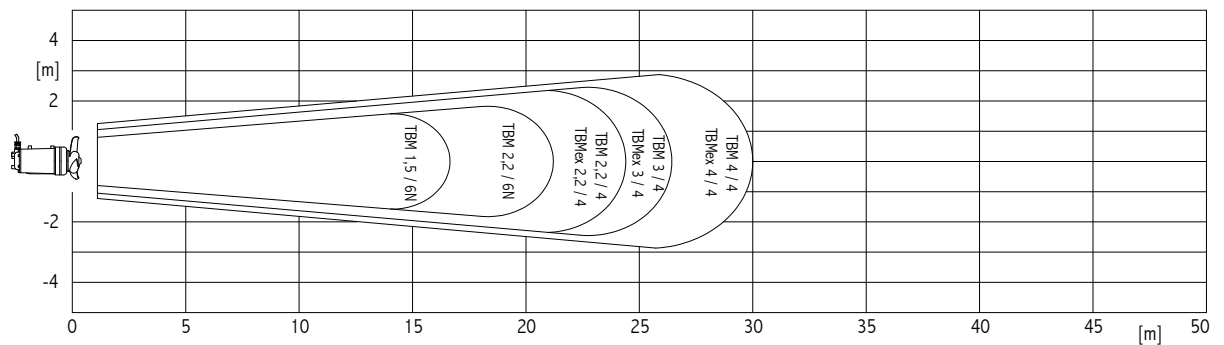

### CARATTERISTICHE STANDARD

Motori elettrici asincroni trifase con rotore a gabbia di scoiattolo.  
N°2 sonde termiche inserite nell'avvolgimento statorico.  
Grado di protezione "IP 68".  
Isolamento classe "F".  
Max profondità immersione 20 m.  
Max contenuto sostanze solide in sospensione 12%.  
Cavo sommergibile in neoprene H07-RN-F.  
pH liquido 5 ÷ 12.  
Max temperatura del liquido pompato 40°C.  
Servizio continuo.

### STANDARD FEATURES

Asynchronous three phase electric motors with squirrel cage rotor.  
N.2 thermic probes installed in the stator winding.  
Protection "IP 68".  
"F" class insulation.  
Max submergence depth: 20 m.  
Max solid content in the liquid: 12%.  
Submersible H07-RN-F neoprene cable.  
Liquid pH 5 - 12.  
Max temperature of pumped liquid: 40°C.  
Continuous service.

### CARACTERISTIQUES STANDARD

Moteurs électriques asynchrones triphasés, rotor à cage d'écuriel.  
N°2 sondes thermiques incorporées dans l'enroulement du stator.  
Degré de protection "IP 68".  
Isolement classe "F".  
Max profondeur d'immersion 20 m.  
Max contenu de substances solides en suspension 12%.  
Max pH du liquide 5 ÷ 12.  
Câble immergé en néoprène H07-RN-F.  
Max température du liquide pompé 40°C.  
Service continu.

CARATTERISTICHE MOTORI TRIFASE - 50Hz - ALIMENTAZIONE 400 V ±10%  
 50 Hz - THREE-PHASE- MOTOR FEATURES - VOLTAGE RATING 400 V ±10%  
 CARACTERISTIQUES DES MOTEURS TRIPHASES - 50Hz - ALIMENTATION 400 V ±10%

CARATTERISTIC. MISCELATORE  
 MIXER CHARACTERISTICS  
 CARACTERISTIQU. MELANGEUR

Standard	Tipo Type Type	Atex II2G ExdbII BT5Gb Ex h IIB T5 Gb	Potenza Mot. Motor Rating Puissance Mot. [kW]	Avvolgimen. Windings Bobinage [V]	Assorbimento Absorption Intensité [A (400V)]	Cavo - Cable - Cable			Avviamento		N° pale Blades N. Pales N.	Giri/min RPM T/min	Portata Capacity Débit [m³/h]	Spinta ass.* Axial force* Poussée axi.* [N]		
						N°cavi N°cables N°cables	N° conduttori cavo N° of wires N° conducteurs câble	[mm²]	Lunghezza cavo Cable length [m] Longueur câble	Diretto Direct Direct					Δ-Δ	
TBM 1,5 / 6N			1,5	230-400	4,2	9 x 1,5	10		Δ	Δ	3	925	643	230		
TBM 2,2 / 6N			2,2		5,9							940	876	313		
TBM 2,2 / 4	TBMex 2,2 / 4	2,2	5,3		323							1333	441			
TBM 3 / 4	TBMex 3 / 4	3	6,4		323							1581	580			
TBM 4 / 4	TBMex 4 / 4	4	400-690	9,1	1	9 x 2,5	10	Δ	Δ-Δ	2	320	2146	853			
TBM 5,5 / 4N	TBMex 5,5 / 4	5,5		12,5							326	2391	981			
TBM 7,5 / 4N	TBMex 7,5 / 4	7,5		15,8							328	3254	1520			
TBM 9 / 4N	TBMex 9 / 4	9		19							328	3628	1826			
TBM 11 / 4	TBMex 11 / 4	11		23,5							351	3977	2158			
TBM 15 / 4N	TBMex 15 / 4	15		30							351	5335	2697			
TBM 18,5 / 4N	TBMex 18,5 / 4	18,5		36							354	6884	3826			
TBM 22 / 4		22		42							3	Δ	Δ-Δ	275	9165	4775
TBM 25 / 4		25		47										275	10138	5369

\* Valori ricavati in accordo alla ISO 21630  
 \* Values according to ISO 21630  
 \* Les valeurs obtenues sont conformes à l'ISO 21630

DIMENSIONI INGOMBRO - OVERALL DIMENSIONS - DIMENSIONS D'ENCOMBREMENT

TBM 1,5 / 6N  
 TBM 2,2 / 6N

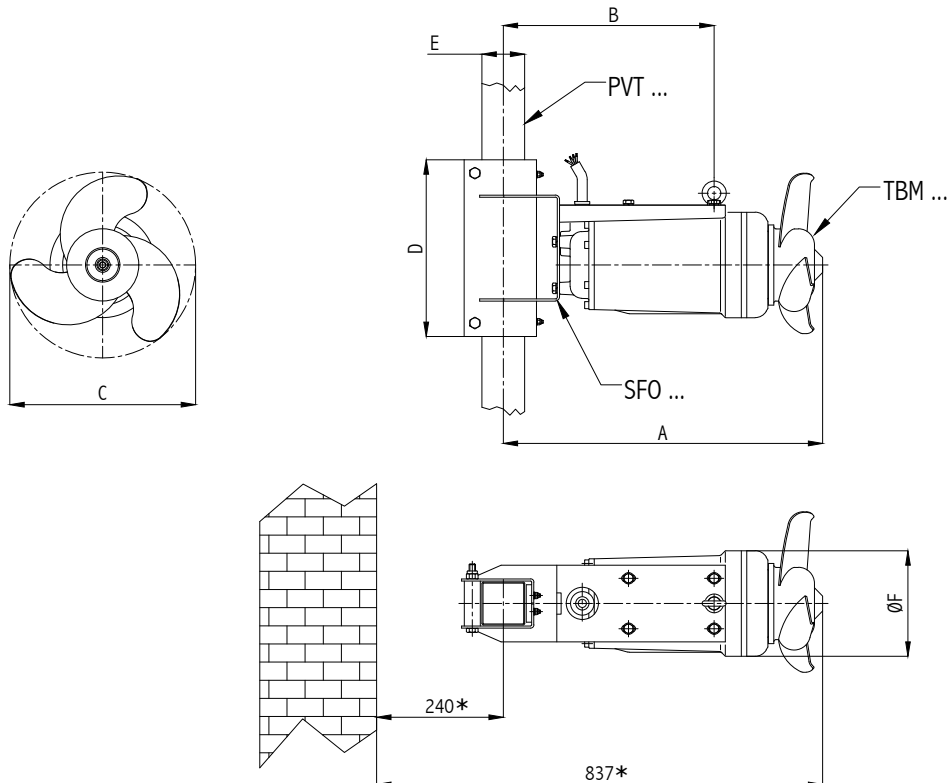

Tipo Type Type	Motore Motor Moteur	DIMENSIONI INGOMBRO OVERALL DIMENSIONS DIMENSIONS D'ENCOMBREMENT [mm]					Peso Weight Poids [kg]
		A	B	C	D	∇E	
TBM 1,5 / 6N	1,5	595	395	297	330	80x80	60,5
TBM 2,2 / 6N	2,2			347			58,5

\* TBM + PVT/GVT + SFO

DIMENSIONI INGOMBRO - OVERALL DIMENSIONS - DIMENSIONS D'ENCOMBREMENT

TBM 2,2 / 4	TBM 5,5 / 4N	TBM 11 / 4	TBM 22 / 4
TBMex 2,2 / 4	TBMex 5,5 / 4	TBMex 11 / 4	TBM 25 / 4
TBM 3 / 4	TBM 7,5 / 4N	TBM 15 / 4N	
TBMex 3 / 4	TBMex 7,5 / 4	TBMex 15 / 4	
TBM 4 / 4	TBM 9 / 4N	TBM 18,5 / 4N	
TBMex 4 / 4	TBMex 9 / 4	TBMex 18,5 / 4	

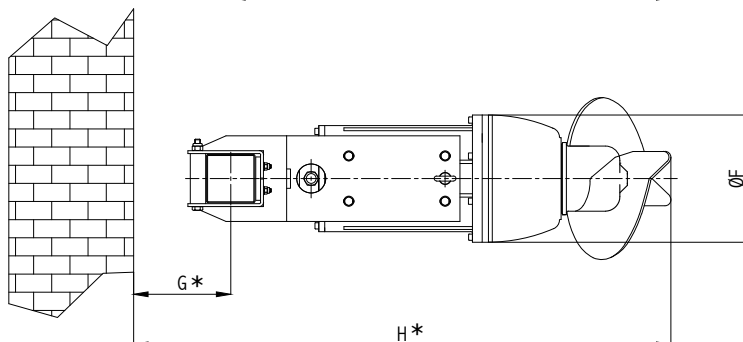
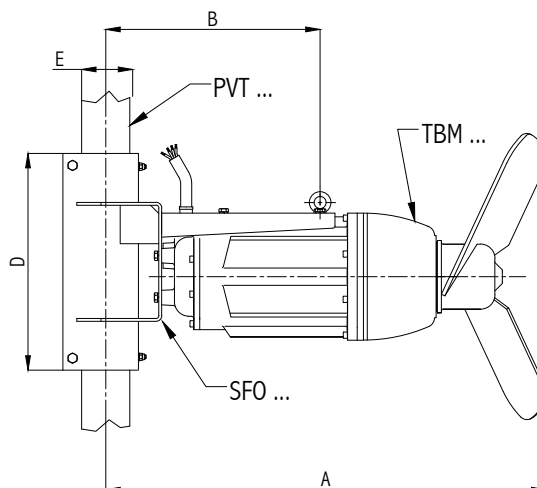
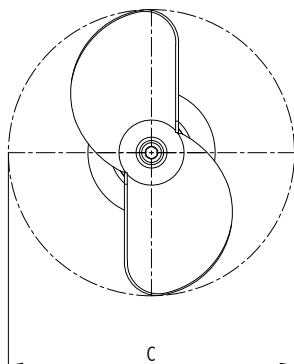

Tipo Type Type	Motore Motor Moteur [kW]	DIMENSIONI INGOMBRO OVERALL DIMENSIONS DIMENSIONS D'ENCOMBREMENT [mm]								Peso Weight Poids [kg]
		A	B	C	D	∅E	F	G*	H*	
TBM 2,2 / 4	2,2	810	395	445	330	80x80	197	240	1050	77
TBMex 2,2 / 4				460			235			79
TBM 3 / 4	3	816	395	460	330	80x80	197	240	1056	79
TBMex 3 / 4				515			235			81
TBM 4 / 4	4	828	395	515	330	80x80	197	240	1068	81
TBMex 4 / 4				535			235			83
TBM 5,5 / 4N	5,5	888	445	535	450	100x100	264	250	1138	115
TBMex 5,5 / 4				585						118
TBM 7,5 / 4N	7,5	999	445	585	450	100x100	264	250	1149	121,5
TBMex 7,5 / 4				595						124,5
TBM 9 / 4N	9	917	445	595	450	100x100	264	250	1157	127
TBMex 9 / 4				600						130
TBM 11 / 4	11	1015	505	600	550	150x150	310	280	1265	185
TBMex 11 / 4				720						189
TBM 15 / 4N	15	1030	505	720	550	150x150	310	280	1280	199
TBMex 15 / 4				780						203
TBM 18,5 / 4N	18,5	1037	505	780	550	150x150	310	280	1287	204
TBMex 18,5 / 4				930						208
TBM 22 / 4	22	1351	725	930	650	150x150	334	280	1631	317
TBM 25 / 4	25	1367		970						325

\* TBM + PVT/GVT + SFO

INSTALLAZIONI POSSIBILI - POSSIBLE INSTALLATIONS - INSTALLATIONS POSSIBLES

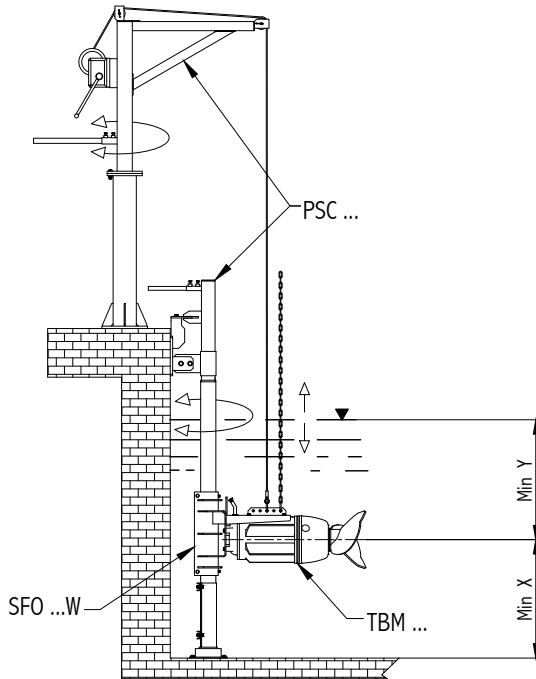

SOMMERGENZA MINIMA RACCOMANDATA RECOMMENDED MINIMUM SUBMERGENCE SUBMERSION MINIMUM RECOMMANDÉE		[mm]	
Tipo - Type - Type	Min X	Min Y	
TBM 1,5 / 6N	500	600	
TBM 2,2 / 6N			
TBM 2,2 / 4	500	700	TBMex 2,2 / 4
TBM 3 / 4			TBMex 3 / 4
TBM 4 / 4			TBMex 4 / 4
TBM 5,5 / 4N	670	750	TBMex 5,5 / 4
TBM 7,5 / 4N			TBMex 7,5 / 4
TBM 9 / 4N			TBMex 9 / 4
TBM 11 / 4	710	850	TBMex 11 / 4
TBM 15 / 4N			TBMex 15 / 4
TBM 18,5 / 4N			TBMex 18,5 / 4
TBM 22 / 4	820	950	
TBM 25 / 4			

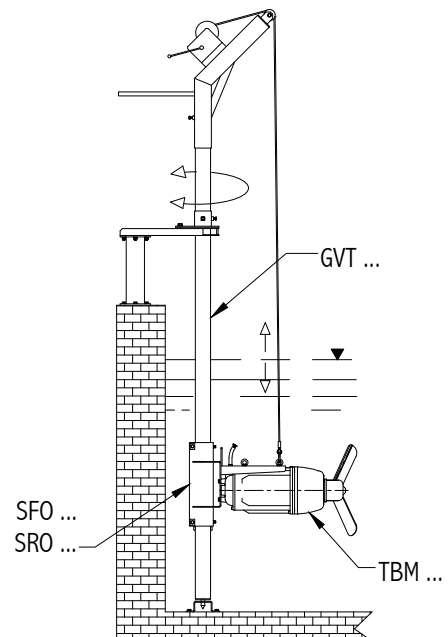
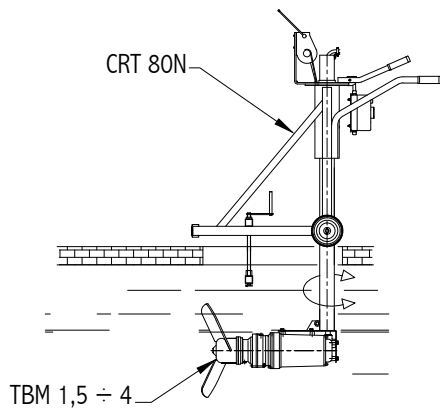
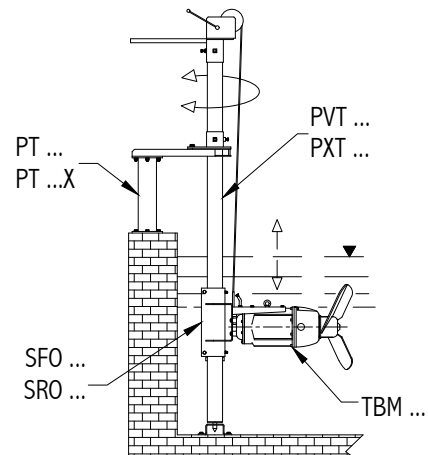
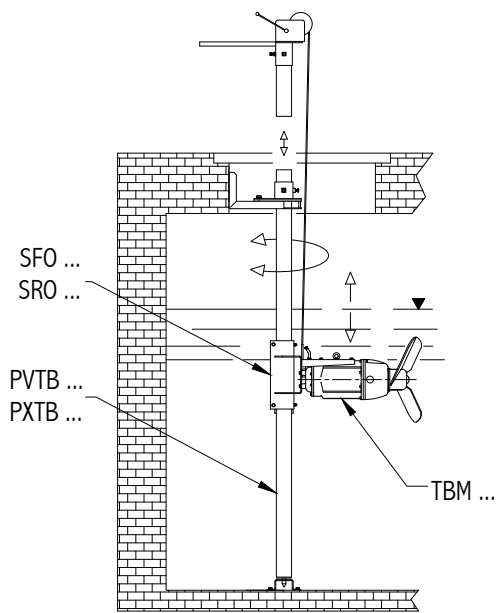

ACCESSORI - ACCESSORIES - ACCESSOIRES

Tipo Type Type	Paranco con verricello e tubo guida Hoist winch and rail pipe Treuril poulie et tuyau guide		Piantone Spacer Colonne	Paranco con verricello e tubo guida Hoist winch and rail pipe Treuril poulie et tuyau guide	
TBM 1,5 - 2,2 / 6N	PVT 80 / 5 PXT 80 / 5	.....	PT 80 PT 80X	PVTB 80 / 5 PXTB 80 / 5	.....
TBM 2,2 - 3 - 4 / 4					
TBMex 2,2 - 3 - 4 / 4					
TBM 5,5 - 7,5 - 9 / 4N	PVT 100 / 5 PXT 100 / 5	.....	PT 100 PT 100X	PVTB 100 / 5 PXTB 100 / 5	.....
TBMex 5,5 - 7,5 - 9 / 4					
TBM 11 / 4	.....	PVT 150 / 5N PXT 150 / 5N	PT 150R	.....	PVTB 150 / 5N PXTB 150 / 5N
TBMex 11 / 4					
TBM 15 - 18,5 / 4N					
TBMex 15 - 18,5 / 4					
TBM 22 / 4					
TBM 25 / 4	PVT 150R / 5	PT 150R	PVTB 150R / 5		

PVT... / PVTB... = Attrezzature con arganello zincato - Equipment with galvanized winch - Équipement avec treuil galvanisé  
PXT... / PXTB... / PT...X = Attrezzature in acciaio inox - Stainless steel equipment - Équipement en acier inoxydable

Tipo Type Type	Paranco con verricello e tubo guida Hoist winch and rail pipe Treuril poulie et tuyau guide		Kit di sollevamento Lifting kit Potence		Fermacavo Cable stop Arrêt de câble
TBM 1,5 - 2,2 / 6N	GVT 80 / 5	.....	KIT PVT 80 KIT PXT 80	.....	FC 16
TBM 2,2 - 3 - 4 / 4					
TBMex 2,2 - 3 - 4 / 4					
TBM 5,5 - 7,5 - 9 / 4N	GVT 100 / 5	.....	KIT PVT 100 KIT PXT 100	.....	FC 20
TBMex 5,5 - 7,5 - 9 / 4					
TBM 11 / 4	.....	GVT 150 / 5N	.....	KIT PVT 150N KIT PXT 150N	FC 26
TBMex 11 / 4					
TBM 15 - 18,5 / 4N					
TBMex 15 - 18,5 / 4					
TBM 22 / 4					
TBM 25 / 4	GVT 150R / 5	.....	KIT PVT 150R	FC 28	

GVT... / KIT PVT... = Attrezzature con arganello zincato - Equipment with galvanized winch - Équipement avec treuil galvanisé  
KIT PXT... = Attrezzature in acciaio inox - Stainless steel equipment - Équipement en acier inoxydable

ACCESSORI - ACCESSORIES - ACCESSOIRES

	Staffa motore Motor bracket Support du moteur	Staffa motore inclinabile Adjustable motor bracket Support réglable du moteur	Carrello per pozzetti Trolley Chariot	Gru con verricello e tubo guida Cranes winch and rail pipe Grues poulie et tuyau guide	Staffa motore con rullini Motor bracket with rolls Support du moteur avec rouleaux
Tipo Type Type					
TBM 1,5 - 2,2 / 6N	SFO 80	SRO 80	CRT 80N	PSC 80 / 5	SFO 80W
TBM 2,2 - 3 - 4 / 4					
TBMex 2,2 - 3 - 4 / 4					
TBM 5,5 - 7,5 - 9 / 4N	SFO 100	SRO 100	.....	PSC 100 / 5	SFO 100W
TBMex 5,5 - 7,5 - 9 / 4					
TBM 11 / 4	SFO 150	SRO 150	.....	PSC 150R / 5	SFO 150W
TBMex 11 / 4					
TBM 15 - 18,5 / 4N					
TBMex 15 - 18,5 / 4	SFO 180	.....	.....	PSC 150R / 5	SFO 180W
TBM 22 / 4					
TBM 25 / 4					

CRT 80N / PSC... = Attrezzature con arganello zincato - Equipment with galvanized winch - Équipement avec treuil galvanisé

	Kit gru con verricello Cranes and winch kit Kit grues et poulie	Kit fissaggio tubo guida Fixing kit for rail pipe Kit de fixation pour tuyau guide	Tubo guida Rail pipe Tuyau carré	Staffa attacco catena e fune Bracket for chain and rope Support pour chaîne et corde
Tipo Type Type				
TBM 1,5 - 2,2 / 6N	KIT PVG 80	KIT PTG 80	KIT PGI 80	SCF
TBM 2,2 - 3 - 4 / 4				
TBMex 2,2 - 3 - 4 / 4				
TBM 5,5 - 7,5 - 9 / 4N	KIT PVG 100	KIT PTG 100	KIT PGI 100	SCF
TBMex 5,5 - 7,5 - 9 / 4				
TBM 11 / 4	KIT PVG 150R	KIT PTG 150R	KIT PGI 150R	SCF
TBMex 11 / 4				
TBM 15 - 18,5 / 4N				
TBMex 15 - 18,5 / 4	KIT PVG 150R	KIT PTG 150R	KIT PGI 150R	SCF
TBM 22 / 4				
TBM 25 / 4	KIT PVG 150R	KIT PTG 150R	KIT PGI 150R	SCF
TBM 25 / 4				

KIT PVG... = Attrezzature con arganello zincato - Equipment with galvanized winch - Équipement avec treuil galvanisé